

COREL[®]



**Streamline your technical
illustration workflow**

Copyright 2006 Corel Corporation. All rights reserved.

Streamline your technical illustration workflow White Paper

Protected by U.S. Patents 5652880; 5347620; 5767860; 6195100; 6385336; 6552725; 6657739; 6731309; 6825859; 6633305; Patents Pending.

Product specifications, pricing, packaging, technical support and information (“specifications”) refer to the retail English version only. The specifications for all other versions (including other language versions) may vary.

INFORMATION IS PROVIDED BY COREL ON AN “AS IS” BASIS, WITHOUT ANY OTHER WARRANTIES OR CONDITIONS, EXPRESS OR IMPLIED, INCLUDING, BUT NOT LIMITED TO, WARRANTIES OF MERCHANTABILITY, SATISFACTORY QUALITY, MERCHANTABILITY OR FITNESS FOR A PARTICULAR PURPOSE, OR THOSE ARISING BY LAW, STATUTE, USAGE OF TRADE, COURSE OF DEALING OR OTHERWISE. THE ENTIRE RISK AS TO THE RESULTS OF THE INFORMATION PROVIDED OR ITS USE IS ASSUMED BY YOU. COREL SHALL HAVE NO LIABILITY TO YOU OR ANY OTHER PERSON OR ENTITY FOR ANY INDIRECT, INCIDENTAL, SPECIAL, OR CONSEQUENTIAL DAMAGES WHATSOEVER, INCLUDING, BUT NOT LIMITED TO, LOSS OF REVENUE OR PROFIT, LOST OR DAMAGED DATA OR OTHER COMMERCIAL OR ECONOMIC LOSS, EVEN IF COREL HAS BEEN ADVISED OF THE POSSIBILITY OF SUCH DAMAGES, OR THEY ARE FORESEEABLE. COREL IS ALSO NOT LIABLE FOR ANY CLAIMS MADE BY ANY THIRD PARTY. COREL'S MAXIMUM AGGREGATE LIABILITY TO YOU SHALL NOT EXCEED THE COSTS PAID BY YOU TO PURCHASE THE MATERIALS. SOME STATES/COUNTRIES DO NOT ALLOW EXCLUSIONS OR LIMITATIONS OF LIABILITY FOR CONSEQUENTIAL OR INCIDENTAL DAMAGES, SO THE ABOVE LIMITATIONS MAY NOT APPLY TO YOU.

Corel, the Corel logo, ActiveCGM, Corel DESIGNER, CorelDRAW, Corel PHOTO-PAINT, CorelTRACE, Designer, Painter, Paint Shop Pro, and WordPerfect are trademarks or registered trademarks of Corel Corporation and/or its subsidiaries in Canada, the U.S., and/or other countries.

Adobe, Illustrator, PostScript, and Reader are registered trademarks of Adobe Systems Incorporated in the United States and/or other countries. AutoCAD, AutoCAD LT, and DXF are either trademarks or registered trademarks of Autodesk, Inc., in the USA and/or other countries. CATIA is a registered trademark of Dassault Systemes in the United States. Microsoft, Visio, and Visual Basic are registered trademarks of Microsoft Corporation in the United States and/or other countries. Pro/ENGINEER is a registered trademark of Parametric Technology Corporation or its subsidiaries in the U.S. and in other countries. SAT is a registered trademark of Spatial Corp. Unicode is a trademark of Unicode, Inc. Other product, font, and company names and logos may be trademarks or registered trademarks of their respective companies.

Contents

Overview	4
Technical illustration challenges	5
General challenges in manufacturing industries	6
Industry-specific challenges	6
Aerospace and automotive industries	6
Telecommunications and utilities industries	8
Apparel design industry	8
Architecture industry	10
Integration with the technical illustrator's workflow	11
Maximizing data integrity	11
Converting legacy designs	12
Customizing the workspace	12
Ensuring precision	13
Using annotations, callouts, and measurements	14
Using the right tools for technical illustration	15
Automating repetitive tasks	15
Importing or exporting illustrations	16
How Corel DESIGNER Technical Suite 12 differs from other graphics solutions	17
Creative graphics and flowcharting applications	17
CAD software	17
Corel DESIGNER Professional	18
About Corel	19



Overview

Using the right tool for the job makes work faster and simpler. Until recently, technical illustrators did not have dedicated software available to help with their specific workflow. Instead, they had to rely on graphics or computer-aided design (CAD) applications to create their documentation, which often resulted in less than accurate instruction manuals. Today, technical illustrators can choose a tool that meets their requirements.

In an increasingly demanding business world, technical illustrators need software that helps streamline their workflow. With Corel DESIGNER® Technical Suite 12, technical illustrators benefit from specialized tools that simplify the creation process. For example, the precision of the Gravity Snapping feature makes it easy to position objects accurately the first time. Customizable symbols ensure the consistency of repeated elements and help to reduce file size. In addition, the user interface is easily customized to suit a particular workflow.

To ensure the seamless transfer of information during collaboration, the suite supports a wide range of file formats for import and export. The value-packed suite also includes Corel PHOTO-PAINT® 12 for photo-editing and CorelTRACE® 12 for bitmap-to-vector conversion, and it is highly compatible with CorelDRAW® Graphics Suite and Micrografx DESIGNER® (versions 3.1 through 9).

As the perfect complement to existing programs and processes, Corel DESIGNER Technical Suite 12 offers consistent and precise tools for creating accurate illustrations. Accurate technical illustrations make it easier, faster, and cheaper to manufacture high-quality products and supporting materials. Corel DESIGNER Technical Suite 12 can help you

- achieve faster product development with shorter time-to-market
- minimize confusion and lost time during production
- simplify quality control and collaboration
- reduce training and education costs
- provide rich communication tools for marketing and sales teams
- improve technical support and customer service

This white paper considers the challenges facing technical illustrators in various industries and provides a roadmap to greater workplace efficiency through the use of Corel DESIGNER Technical Suite 12.



Technical illustration challenges

Technical illustrations must adhere to several restrictive parameters that are not faced by designers of creative illustrations or business graphics. Technical illustrations must be accurate, definitive, and informative. Perspective is used not just to produce a visual effect, but to convey information. Text labels must be easy to update, and they require precise placement so that other information is not obscured.

Often, technical illustrators work from complex CAD models of components, or from databases of parts numbers and specifications. When such data is imported into technical illustration software, the retention of detail, dimensions, and other information is critical.

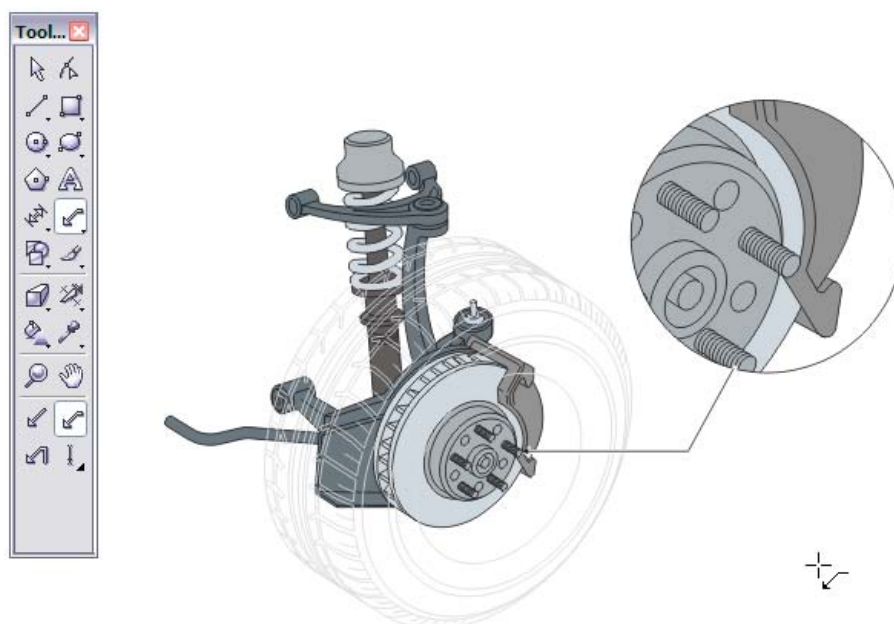

To help meet these challenges, Corel DESIGNER Technical Suite 12 was designed to integrate with the workflow of technical illustrators. To achieve this, Corel consulted with customers from various manufacturing industries to learn more about their challenges. In helping to meet the challenges defined by customers, Corel DESIGNER Technical Suite 12 fills the gap between the CAD systems used for product design and the creative or business graphics software used throughout an organization.

For more specific information on how Corel DESIGNER Technical Suite 12 integrates with the technical illustrator's workflow, refer to the section "Integration with the technical illustrator's workflow" on pages 9–13.



General challenges in manufacturing industries

In manufacturing and design industries, technical illustrations are often the most widely used aspect of the specification. Technical illustrators need software that helps them transform complex designs and schematics into easily interpreted graphics that are suitable for reuse across the organization. High-quality, accurate illustrations enable strong communication through all stages of the product life cycle: design and development, marketing, sales force training, technical support, and customer service.

Technical illustration software must also support multiple output options and professional color separation. Assembly diagrams, maintenance manuals, installation guides, and other technical guides are usually printed in black and white, whereas product flyers, parts catalogs, sales presentations, and other collateral are usually printed in color. In addition, several manufacturing industries are moving to electronic documentation for field use, often with supporting paper documentation. As a result, technical illustration software must support HTML, SVG, and other Web publishing standards, such as CGM.

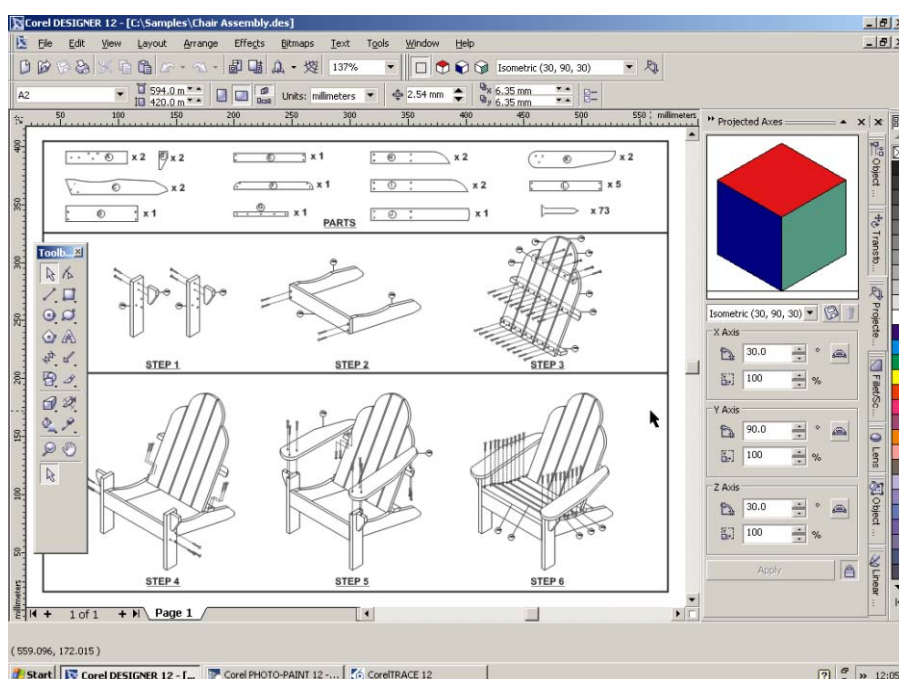

Industry-specific challenges

Some of the challenges faced by technical illustrators depend on their specific industrial field. Corel DESIGNER Technical Suite 12 can help technical illustrators increase their productivity by addressing the unique requirements that arise within individual industries.



Aerospace and automotive industries

In the aerospace and automotive industries, design engineers typically work on smaller, specific components of a larger schematic. They may also spend significant time fine-tuning their designs and working with isometric drawings. Often, this happens in collaboration with the 3D CAD engineers, who are responsible for putting together all component designs for an entire aircraft or car.

Iterative design and repurposing

Engineers may design a component from scratch, or they may import a CAD file to use as the foundation for a design. They may even use older, paper-based designs, which are scanned and traced to create editable vector images. Throughout every design process, the level of collaboration varies. Precision engineering means that components must work together seamlessly, with very narrow tolerances. The size of an entire vehicle schematic can present challenges in clearly displaying details at reduced views.

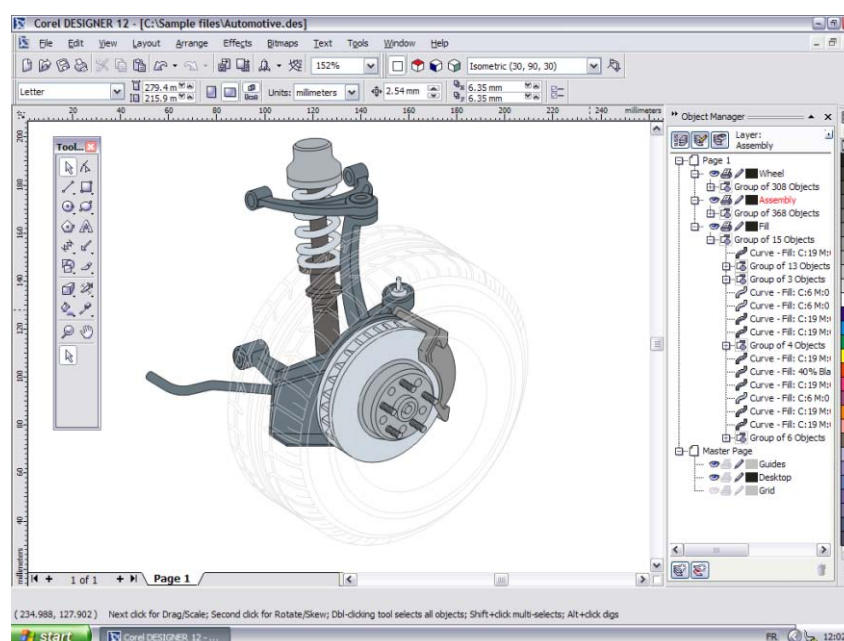

The documentation for a vehicle design can exceed 5,000 pages. It may include a complete catalog of spare parts, isometric images of individual components, pictograms, 2D schemas, exploded drawings, assembly diagrams, and general plans. Depending on customer requirements and industry regulations, documentation may have to be made available in multiple formats: paper, PDF, CD-ROM, and HTML.

Corel DESIGNER Technical Suite 12 helps technical illustrators meet these challenges by integrating with their workflow. Support for an array of industry-standard file formats, including AutoCAD® DXF™ and DWG, ensures the seamless exchange of information. Technical illustrators can import and edit isometric drawings. CorelTRACE automatically converts bitmaps to vectors, making it easy to reuse older designs. In addition, specialized precision drawing features help increase productivity without compromising accuracy.



Telecommunications and utilities industries

In the telecommunications and utilities industries, systems engineers spend a large proportion of their time creating and modifying schematic diagrams. Typically, this is done in collaboration with colleagues from across the company.

Creating schematics

Some diagrams are based on existing designs; others are drawn from scratch. However, they all use a repeated range of elements and symbols that are linked to parts numbers in a spreadsheet or database. The engineer usually needs to incorporate customer or system information from documents contributed by other departments. This information is often created by a variety of applications.

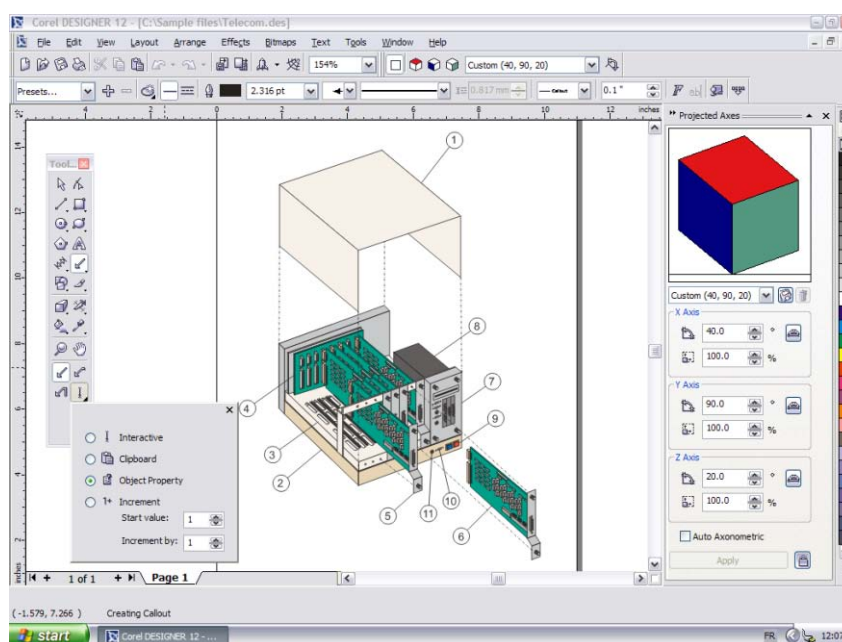

Corel DESIGNER Technical Suite 12 supports a wealth of industry-standard file formats, which makes it easy to share information with colleagues. The extensive Symbols library is beneficial for working with complex designs that contain repeated elements. With the Symbols Manager, technical illustrators can create and share their own custom symbols. A symbol can be modified and updated dynamically so that the change is represented in any design in which the symbol appears. This capability in Corel DESIGNER Technical Suite 12 provides significant time savings for an entire team of technical illustrators.

Apparel design industry

In the apparel design industry, collaboration and compatibility are key. Clothing designers regularly work with production engineers, sales representatives, fabric designers, and manufacturers. Typically, they take design and pattern direction from a merchandising team whose members are in a different location. For production and quality control decisions, a manufacturing team in yet another location must be consulted.

Increasingly, product pattern designs are linked with data management systems to integrate information from design, engineering, and manufacturing teams. For the clothing designer, it is imperative that software can import and export projects in a variety of file formats.

Creating symmetrical patterns

Pattern pieces for clothing are frequently symmetrical. Designers usually copy a pattern line from one side and mirror it on the opposite side. Therefore, updating a pattern with numerous alterations during the design process can be slow and tedious. Significant time is also required to align and distribute intricate design items such as buttons and stitching marks. For workflow efficiency, illustration software needs to support custom line styles, which ease the process of using unique stitching marks.

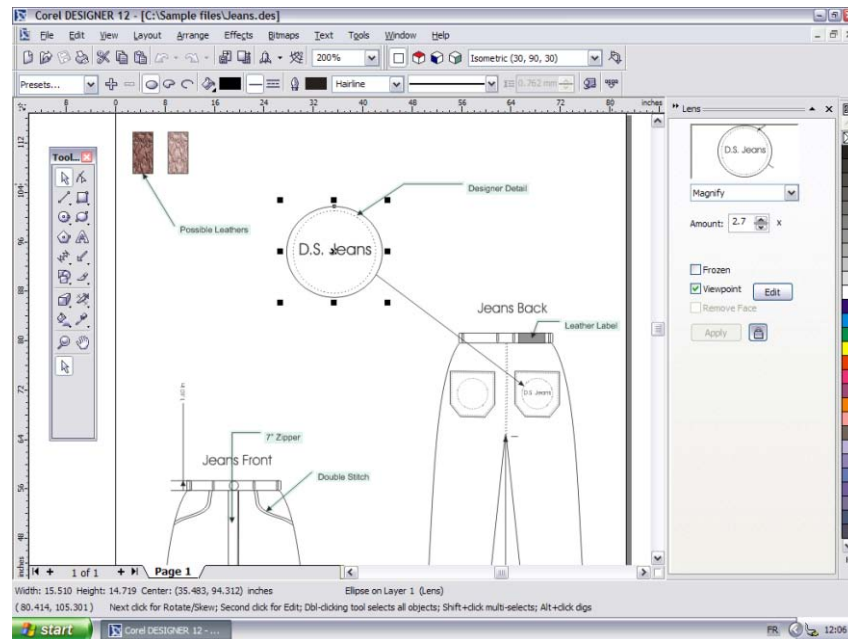

Many of these pattern elements are reused throughout an organization, especially during product line presentations. In addition to the design patterns, presenting a product line requires sample illustrations, design patterns, storyboards, and pricing information. If digital textile printing is used for creating samples, precise measurements and color fidelity are critical. Therefore, clothing designers must be able to share with colleagues any basic pattern elements, common pattern pieces, and detailing — such as trims and logos.

Corel DESIGNER Technical Suite 12 supports an array of industry-standard file formats to facilitate collaboration across an organization. Technical illustrators can export a design or a portion of a design to one of many file formats, depending on the project's requirements. Specialized drawing features, such as enhanced line styles, gravity snapping, and dynamic guides help increase productivity and ensure precision. In addition, the Symbols Manager lets technical illustrators create custom symbols, use them repeatedly in many designs, and modify an original symbol just once to reflect the change in each symbol instance.



Architecture industry

In addition to producing standard planning diagrams, architects are called on to design the site plans, floor plans, space plans, and elevations. Architects work from a wide range of information, which includes on-site measurements, planning requirements, standard materials and fittings, and client specifications.

Evolving plans and projections

Traditional physical models are gradually being replaced by projections and 3D renderings of the final design. Like the working sketches, plans, and specifications, these items require updating throughout a project. Often, the projections and 3D renderings are used for the planning submission, marketing collateral, and the completed project. As e-Government initiatives increase worldwide, more planning departments are asking for plans to be submitted electronically in a wide variety of formats.

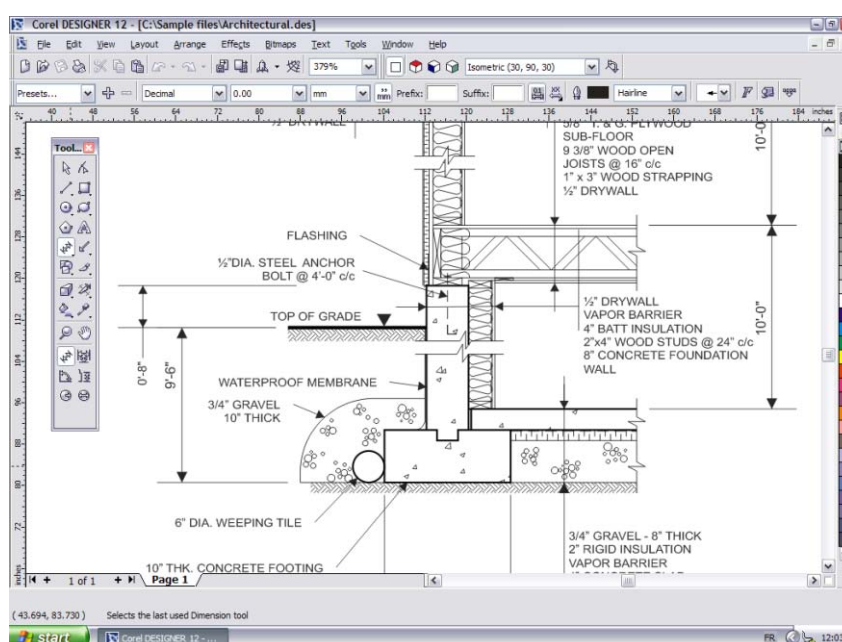

Architectural plans reflect the mechanical, electrical, and structural needs of a building. As the design evolves and contractors submit bids, the parts lists must be synchronized with cost estimates. Throughout a project, both drawing and labeling tools need to be accurate — especially to ensure proper construction and to comply with industry regulations. Hatch fills help differentiate between materials and coinciding objects, and they can be used to indicate different types of materials, such as flooring.

With support for more than 75 industry-standard file formats, Corel DESIGNER Technical Suite 12 ensures data integrity and makes it easy to work with information from disparate sources. By using projected drawing modes, technical illustrators can reduce the necessary steps for creating and modifying 3D projections and can simply draw on the projected plane. In addition, exceptional callout features make it easy to label the most complex designs accurately.



Integration with the technical illustrator's workflow

Corel DESIGNER Technical Suite 12 was conceived with a specific focus on the technical illustrator's needs for design precision, collaboration efficiency and flexibility, and the ability to repurpose legacy data and drawings. Whether they are designing for the aerospace, automotive, telecommunications, or apparel industry, technical illustrators will find that Corel DESIGNER Technical Suite 12 offers them unique benefits.

The creation of technical illustrations can be complex, especially when designs are intended to serve multiple departments within an organization. The diagram for a single part may need to be used in product documentation and repurposed for use in marketing materials. In such cases, it is critical for users to be able to collaborate with internal and external department resources and work seamlessly with external data in various file formats.

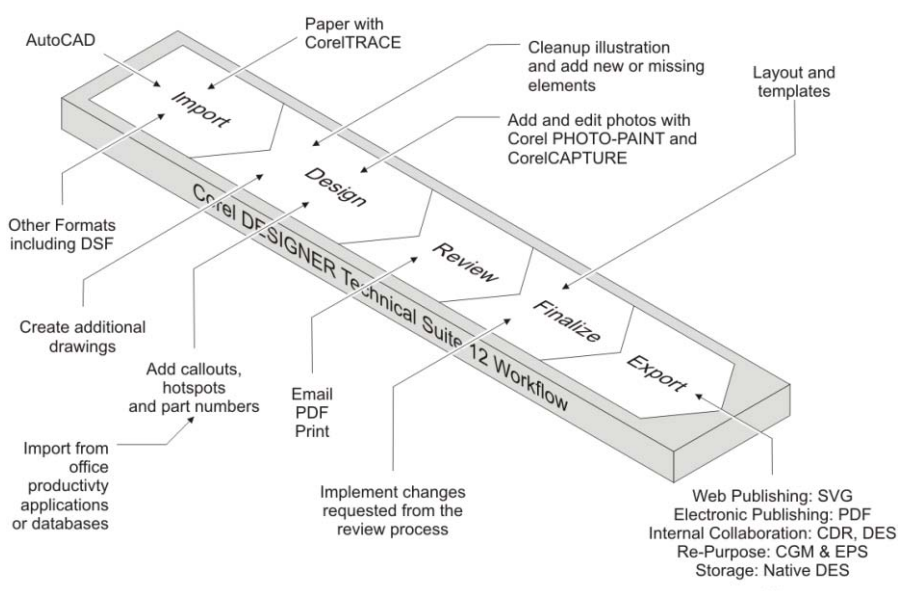

Corel DESIGNER Technical Suite 12 integrates with the technical illustrator's workflow.

Maximizing data integrity

Today, most technical illustrations originate from data created by CAD engineers. Typically, this data details the technical component of a product and can range from legacy designs to new perspective views. Often, a technical illustrator uses multiple applications before finishing a design. The ability to exchange information between applications without losing data is critical to a technical illustrator's workflow.

Corel DESIGNER Technical Suite 12 perfectly complements AutoCAD by providing tools and features that support the workflow of technical illustrators. It supports more than 75 file formats, including DXF, DWG, SVG, CGM, CDR, PDF, PSD, TIFF, AI, EPS, DOC, XLS,

and more. In addition, Corel DESIGNER Technical Suite 12 lets users import Corel DESIGNER 9 and Micrografx Designer files (DSF), including versions 3.1 through 9.

Converting legacy designs

Before the days of CAD and other illustration software, technical illustrators relied on old-fashioned India ink to put their designs on paper. In order for many of these older designs to be used today, they must be scanned to create a bitmap image. The bitmaps are then traced to form editable vector images. To save time and effort, Corel DESIGNER Technical Suite 12 includes CorelTRACE 12, a bitmap-to-vector tracing utility. CorelTRACE automatically converts scanned or manually created bitmaps into vector images and seamlessly imports them into Corel DESIGNER.

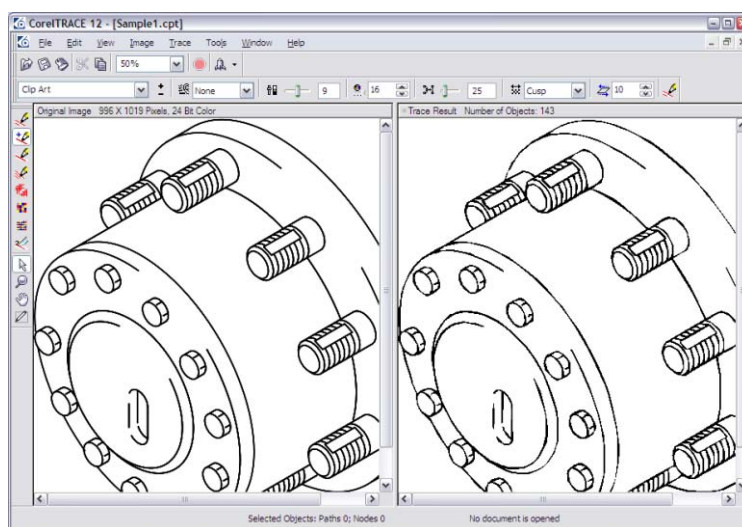

CorelTRACE enables bitmap-to-vector conversion, making it easy to reuse older, paper-based designs.

Customizing the workspace

With a customizable user interface, Corel DESIGNER Technical Suite 12 lets technical illustrators streamline the available toolset to match their workflow. They can quickly and easily tailor the interface menus, commands, shortcut keys, and toolbars. For network deployments, Dynamic Language Switching makes it easy to deploy and use the application in any of its supported languages.

The Workspace Selector includes preconfigured workspaces that resemble the look and feel of Adobe® Illustrator®, Micrografx Designer 9, and Microsoft® Visio®. In addition, users can create, save, and share their own custom workspaces. For example, users can create different workspaces that are specific to their review and design processes.

Ensuring precision

To a technical illustrator, precision is everything. Approximation is not an option, regardless of whether a design is intended for the aerospace, automotive, apparel, or telecommunications industry. All objects must be perfectly aligned with each other. With

their hectic workflows, technical illustrators cannot afford to waste time by zooming in and out to double-check object positioning.

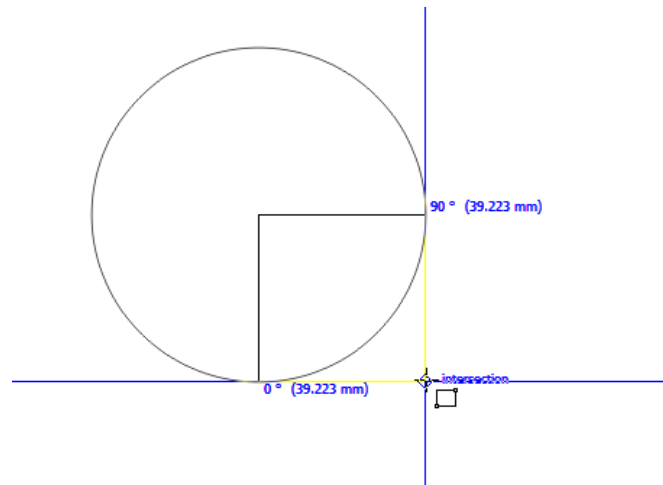

Gravity snapping enables accurate object placement.

Corel DESIGNER Technical Suite 12 provides exceptional tools for ensuring the accuracy of technical illustrations. Gravity snapping lets users snap to various points in objects, making it easy to create and position objects accurately. Technical illustrators can now snap to perpendicular and text baseline points as well.

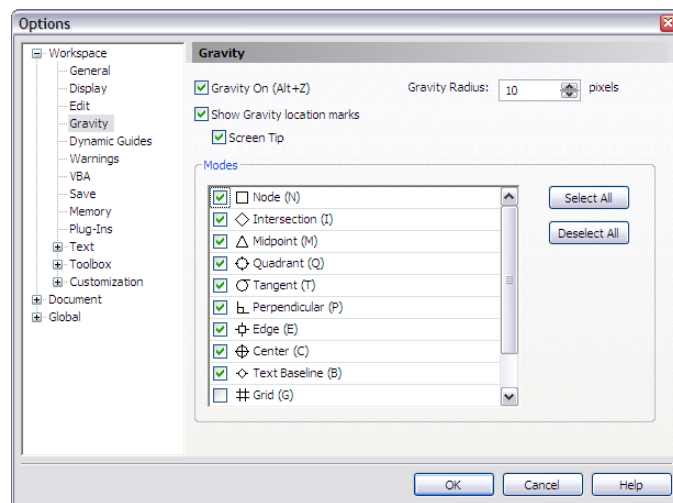

Users can customize the behavior of gravity snapping.



Dynamic guides are temporary guidelines that illustrators can pull from the following snap points in objects — center, node, quadrant, and text baseline. Dynamic guides can be displayed as tangent, perpendicular, or parallel to objects. In addition, parallel dynamic guides makes it easy to draw parallel lines or objects.

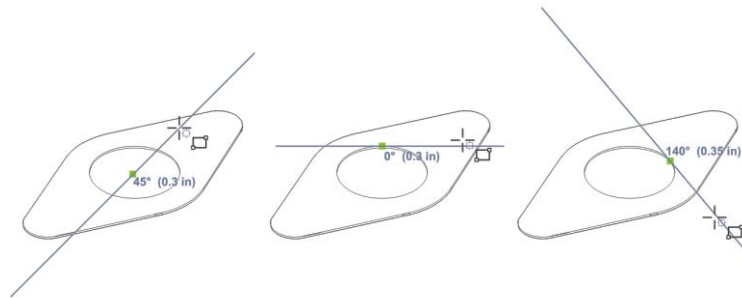

Dynamic guides provide unrivaled precision.

Using annotations, callouts, and measurements

Technical illustrations require detailed annotations, callouts, and measurements. These items may include information about product parts numbers, links to other drawings, and descriptions of functionality. Corel DESIGNER Technical Suite 12 provides enhanced tools for creating and modifying callouts and dimension lines, with simple or advanced options. For example, adding a halo to a callout creates a mask behind the leader line, which makes it easier to see callouts on top of other objects.

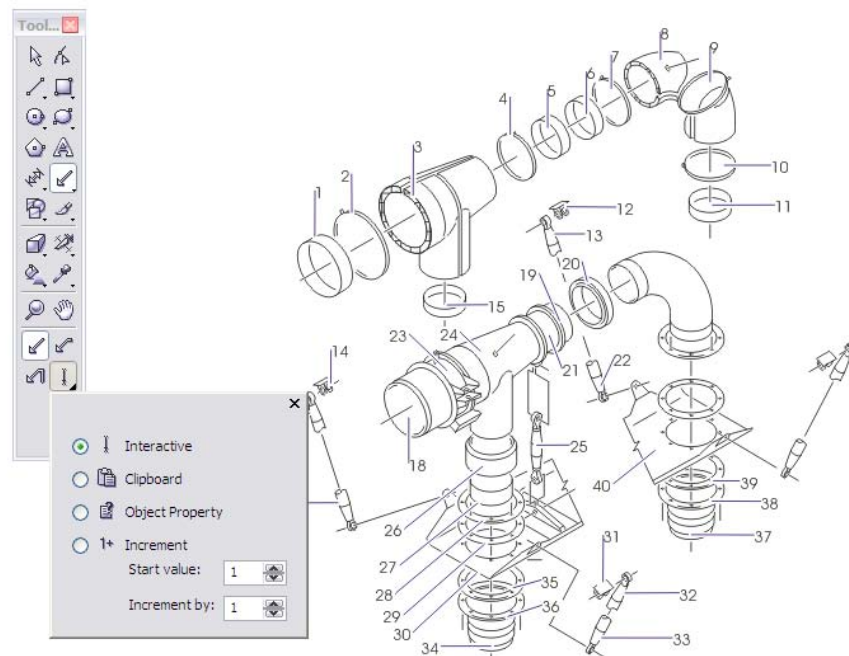

Callouts make it easier to interpret complex illustrations.

Using the right tools for technical illustration

The projected drawing modes, which use predefined drawing profiles to represent three-dimensional objects in two dimensions, dramatically increase productivity. Technical illustrators can actively draw on the projected plane, eliminating the need to draw the object first and then project it in a second step.

Particularly useful for drawing stitching patterns, enhanced line styles allow technical illustrators to create lines of a specific width and pattern. The enhanced line styles were developed as a direct result of user feedback in the apparel industry. In addition, hatch fills provide an easy method of differentiating material types. For example, technical illustrators in the architecture industry can use hatch fills to indicate various flooring materials.

Frequently, an illustration may be localized and contain text in several different languages. To that end, Corel DESIGNER Technical Suite 12 supports Unicode™ text, which allows users to work with multilingual documents.

Automating repetitive tasks

Many technical illustrators spend countless hours on repetitive tasks, such as hotspotting, creating lists of parts, and changing parts numbers. Corel DESIGNER Technical Suite 12 can help streamline the technical illustration workflow by including Microsoft® Visual Basic® for Applications (VBA) and an array of industry-standard symbols.

VBA lets technical illustrators automate repetitive tasks and enables easy interaction between data and objects for creating hotspots and parts lists. VBA also allows the creation of add-ons and extensions, which can help tailor Corel DESIGNER to suit a particular workflow.

To allow easy placement of screws, nuts, bolts, and threading, Corel DESIGNER Technical Suite 12 includes more than 4,000 industry-standard symbols. In addition, technical illustrators can create and share customized reusable symbols that can be accessed over a corporate network. This ability enables dynamic updates, so that when a symbol is modified by another illustrator, all designs using that symbol are easily updated to reflect the change.

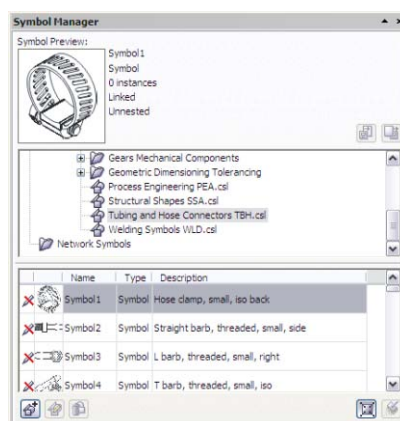

The Symbol Manager makes it easy to reuse objects.



Importing or exporting illustrations

Whether technical illustrators are importing a file or exporting a finished design, data loss is not an option. Industry-standard file formats are mandatory to ensure easy deployment and sharing of files. Corel DESIGNER Technical Suite 12 supports more than 75 industry-standard import/export filters, including WebCGM, ActiveCGM®, GREX-CGM (ATA), and SVG filters. Technical illustrators can also import and export to a variety of bitmap formats, including TIFF, GIF, JPEG, PNG, CDR, CPT, and RIF.

Users can easily create a PDF of a design without having to purchase additional software. PDF files are viewable on any computer with the freely distributed Adobe® Reader®. To ensure perfect printing results, Corel DESIGNER Technical Suite 12 also features a color management system and advanced preflight capabilities.

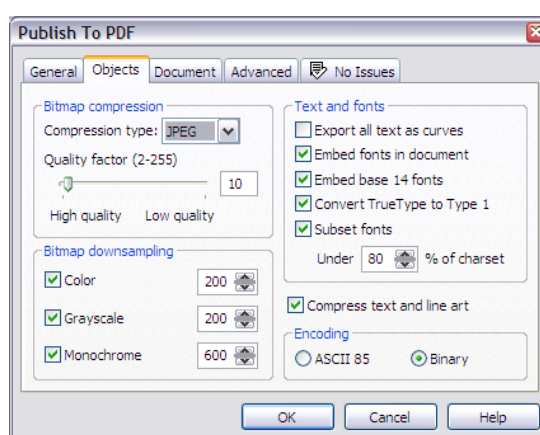

Technical illustrators can export illustrations to PDF without purchasing additional software.



How Corel DESIGNER® Technical Suite 12 differs from other graphics solutions

In addition to providing many of the design tools found in other creative graphics applications, such as CorelDRAW Graphics Suite and Adobe Illustrator, Corel DESIGNER Technical Suite 12 offers unique benefits to technical illustrators.

Corel DESIGNER provides workflow-integrated tools that can dramatically increase the productivity of technical illustrators. It offers precision drawing and object placement tools, exceptional callout and dimension tools, many additional creative features, outstanding ease of use, and flexibility for collaboration. Projected drawing modes, hatch fills, Virtual Segment Delete, dimensions, and measurements are just a few of the specialized features that Corel DESIGNER provides for technical illustration.

Creative graphics and flowcharting applications

Creative graphics, page layout, and flowcharting applications provide powerful tools for creative professionals, graphic designers, and general business users. However, these applications do not provide the features necessary to create accurate technical illustrations for product documentation.

For example, technical illustrations rely on callouts to provide additional information about specific objects, such as parts numbers, magnifying effects, or text descriptions. A key requirement for technical illustrations is that halos surround callouts. Halos are white spaces that make the callouts easier to identify and read in complex graphics. Creating halos with creative graphics or flowcharting applications requires 10 to 15 steps. With the specialized features provided by Corel DESIGNER, however, halos are created in one step.

CAD software

CAD software, such as AutoCAD or AutoCAD LT®, is meant to help engineers and architects with their designs. CAD engineers need tools for creating solid models, wireframes, and wiring diagrams. They often run simulations and validations to compare their design to specifications. In addition, CAD engineers need to output bills for materials and manufacturing.

The technical illustration workflow is very different from that of a CAD engineer. The CAD output is often used by manufacturing and can be complex and difficult to interpret. Technical illustrators must convert these CAD designs into easily understood graphics that can be reused throughout an organization's product development cycle.



Corel DESIGNER Technical Suite 12 works with output from CAD software and offers many specialized features for technical illustrations, including the following:

- superb AutoCAD 2004 DXF and DWG filters, for importing CAD designs
- Virtual Segment Delete, for quick and accurate simplification of CAD designs
- callout, dimension, and measurement features, for providing additional information about specific objects
- professional photo-editing capabilities, for combining vector and bitmap graphics
- Projected drawing modes, for offering different views of objects
- CorelTRACE[®], for converting scanned legacy drawings into editable vector graphics
- advanced printing and color management capabilities, for producing a professional output
- multiple export options, for ensuring that illustrations are easily shared throughout an organization, including Web formats (PDF, SVG, CGM, and HTML), encapsulated PostScript[®] (EPS), CDR, AI, TIFF, GIF, and JPEG.

Corel DESIGNER[®] Professional

Specific industries, such as automotive, aerospace, and defense, need high-end capabilities for working with CAD files. To that end, Corel DESIGNER[®] Professional provides support for 3D CAD drawings, including CATIA[®] 4, CATIA 5, Pro/ENGINEER[®], IGES, and SAT[®] formats.

Developed in partnership with Spatial Technologies, Corel DESIGNER Professional enables integrated manipulation, rotation, positioning, and cutting of 3D objects to a projected view. The corresponding isometric or customized projection can include hidden lines and varying line thickness. Corel DESIGNER Professional also offers the unique ability to open and rotate 3D vector files. In addition, users can freeze the 2D display at a specific orientation for further editing. These capabilities eliminate the need for additional CAD software licenses and related training.



About Corel

Corel Corporation provides innovative software solutions that help millions of value-conscious businesses and consumers in more than 75 countries improve their productivity. Corel is renowned for its powerful software portfolio, which combines innovative photo-editing, graphics creation, vector-illustration, and technical-graphics applications with office and personal productivity solutions. Corel's flagship products include CorelDRAW® Graphics Suite, Corel® WordPerfect® Office, Corel® Paint Shop Pro®, Corel® Painter™, and Corel DESIGNER® Technical Suite. For more information, please visit www.corel.co.uk.





www.corel.co.uk

Corel Corporation

1600 Carling Avenue
Ottawa, ON
Canada
K1Z 8R7

Corel UK Limited

Sapphire Court
Bell Street
Maidenhead
Berkshire SL6 1BU
United Kingdom

Corel Minneapolis

Paint Shop Pro
7905 Fuller Road
Eden Prairie, MN
55344 USA